

2MP 20x IR Network PTZ Dome Camera

IPC6222ER-X20(P)-B



Key Features

Optics

- Accurate and fast focusing
- The third-generation infrared technology
- Smart IR, up to 150 m (492ft) IR distance
- Optical glass window with higher light transmittance
- IR anti-reflection window to increase the infrared transmittance

Compression

- H.265, H.264, MJPEG
- Embedded smart algorithm
- Triple streams
- Customized OSD

Network

- ONVIF Conformance

Structure

- Special structure and window design to battle bad weather (especially in dusty weather)
- Innovative snow-removing functionality

- More effective heat dissipation system
- Intelligent temperature control technology
- 6 KV surge protection designed for network interface

Specifications

	IPC6222ER-X20-B	IPC6222ER-X20P-B
Camera		
Sensor	1/3", 2megapixel, progressive scan, CMOS	
Lens	5.2 ~ 104 mm (20x optical zoom)	
Angle of View (H)	61.9° (wide) ~ 3.5° (tele)	
Shutter	Auto/Manual; shutter time: 1/6 s ~ 1/100000 s	
Minimum Illumination	Colour: 0.03 lux (F1.5, AGC ON) 0 lux with IR	
Iris	Auto/Manual; F1.5 ~ F3.0	
Day/Night	IR-cut filter with auto switch (ICR)	
S/N	>52dB	
WDR	Digital WDR	
Video		
Max. Resolution	1920 × 1080	
Video Compression	H.265, H.264, MJPEG	
Frame Rate	1080P (1920×1080):Max.30 fps; 720P (1280×720):Max.30 fps; D1 (720×576):Max.30 fps	
Video Streaming	Triple	
HLC	Supported	
Evaluative Metering	Supported	
OSD	Up to 8 OSDs	
Privacy Mask	Up to 8 areas	
Digital Zoom	Supported	
Smart		
Behavior Detection	Intrusion, crossing line, motion detection	
Exception Detection	Audio detection	
Intelligent Identification	Face detection	
Statistical Analysis	People counting	
Audio		
Audio Compression	G.711	
Two-way audio	Supported	
Storage		
Edge Storage	Micro SD, up to 128 GB	
Network		
Protocols	L2TP, IPv4, IGMP, ICMP, ARP, TCP, UDP, DHCP, PPPoE, RTP, RTSP, RTCP, DNS, DDNS, NTP, FTP, UPnP, HTTP, HTTPS, SMTP 802.1x	
Compatible Integration	ONVIF, API	

Pan & Tilt	
Pan Range	360° (endless)
Pan Speed	0.1°/s ~ 240°/s
	Preset speed: 300°/s
Tilt Range	-15° ~ +90° (auto reverse)
Tilt Speed	0.1° ~ 160°/s
	Preset speed: 240°/s
Number of Presets	256
Patrol	Up to 16 patrols, up to 32 presets per patrol Note: The total number of patrols and patterns is 16.
Pattern	Up to 16 patterns, with the total recording time not less 15 minutes per pattern
Interface	
Audio I/O	Audio cable
	Input: impedance 35 kΩ; amplitude 2 V [p-p]
	Output: impedance 600 Ω; amplitude 2 V [p-p]
Alarm I/O	1/ 1
Network	10M/100M Base-TX Ethernet
General	
Power	24 V AC, 24 V DC
	24 V AC, 24 V DC, PoE (PSE Required)
	Power consumption: 9 ~ 42W
Dimensions(∅xH)	∅227x359.4 mm (∅8.9" x 14.2")
Weight	5.28 kg (11.6lb)
Working Environment	-40°C ~ +65°C (-40°F ~ 149°F), Humidity ≤ 95% RH(non-condensing)
Ingress Protection	IP66

Dimensions

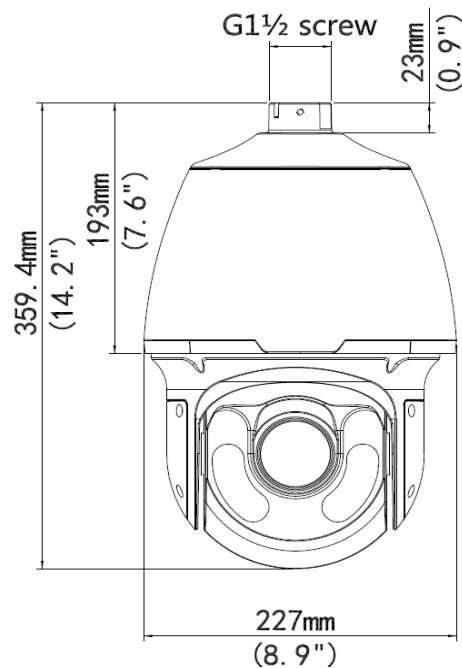

Installation

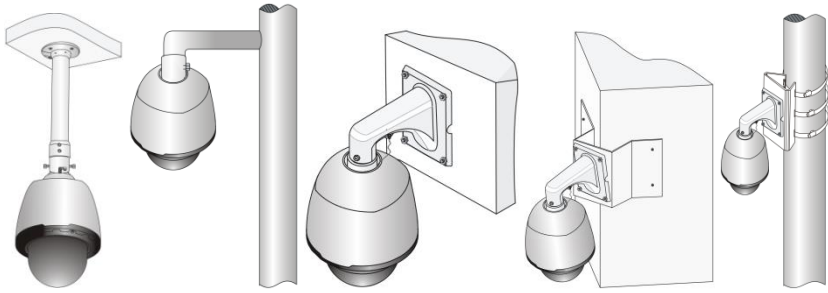

Pendant mount

Standing pole mount

Wall mount

Corner mount

Pole mount

Accessories

Installation mode	Accessories	Description
Pendant mount	TR-CE45-IN bracket	/
	Pendant components: TR-UF45-A-IN ceiling plate TR-SE45-IN pendant rod (200mm) TR-SE45-A-IN pendant rod (500mm)	Ceiling plate is optional with different pendant rod for various applications
Standing pole mount	Customized bracket	The interface is designed with internal G1½ screws. The screw depth must be more than 23 mm.
Wall mount	TR-WE45-IN bracket	/
Corner mount	TR-WE45-IN bracket +TR-UC08-A/B-IN bracket	/
Pole mount	TR-WE45-IN bracket +TR-UP08-A/B-IN bracket	/
PoE Power	Accessories	Description
PSE Adapter	PWR-DC5611-P	PSE Adapter (60W)configuration is needed.

Zhejiang Uniview Technologies Co., Ltd.

South Tower, Building 10, Wanlun Science Park, 88 Jiangling Road, Hangzhou, P.R.China 310051

Email: overseasbusiness@uniview.com; globalsupport@uniview.com

<http://www.uniview.com>

©2016 -2017Zhejiang Uniview Technologies Co., Ltd. All rights reserved.

*Product specifications and availability are subject to change without notice.